



# THE GREEN GENERATION OF PEDESTRIAN DOOR AUTOMATIONS

With only Brushless motors in direct drive and extended range power supply  
100-240 V (50/60 Hz) Switch Mode technology



THE FIRST ENERGY SAVING AUTOMATIONS THAT REDUCE  
ENERGY CONSUMPTION BY OVER 50%



## EFFICIENT

Face automations reduce energy consumption by 50%\*. This extraordinary result has been achieved by the switch mode technology and by the elimination of the gearbox thanks to the direct connection between the brushless motor and the belt.

## SILENT

The configuration without motor gear, the specific design of the profile and of the carriage wheels guarantee the maximum level of silence.

## RELIABLE AND WITH LOW MAINTENANCE COSTS

Reliability has been maximized: the motor works at low speed so it is not subject to wear, supercapacitors have a lifespan seven times longer than standard batteries, the encoder is protected inside the motor shell and the motor-gear is simply not present at all.

## USER-FRIENDLY AND EASY TO INSTALL

Everything has to be as simple as possible: the mechanical installation, the fixing sensor device, the integrated display, the USB connection for the firmware update, the upload/download of the settings, the configurable terminals and the remote-control system.

## EMERGENCY REDUNDANT VERSION

A redundant system with a double winding direct drive motor and an additional emergency card make FACE automations suitable for escape routes, in compliance with EN16005.



Direct drive brushless motor



Supercapacitor opening device

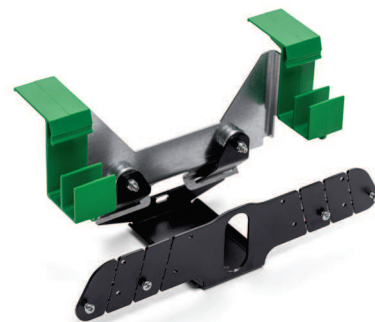

Sensor fixing device

\*Tests performed comparing a SL5 double-leaf sliding door with a traditional automation with CC brush motor, gear reduction and a traditional transformer.

# SLIDING DOOR SL5

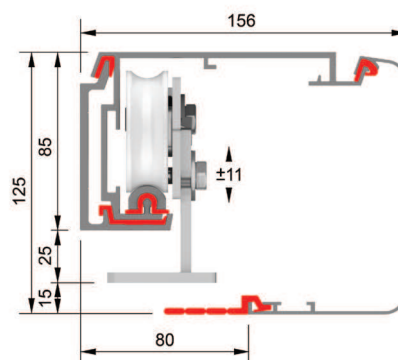
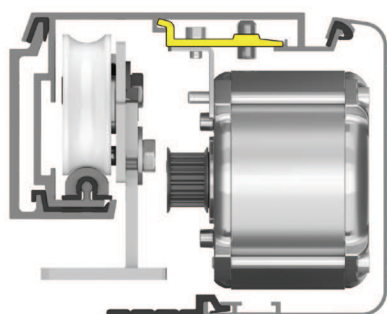

## SILENT

The configuration with three gaskets, together with the brushless motor in direct drive, makes **SL5** absolutely silent.

## EASY MAINTENANCE

The configuration without motor-gear makes **SL5** extremely reliable and with high performances, minimizing the need of maintenance. The brushless motor is covered by a 5-year warranty and the automation is tested for 5 million cycles.

## EASY TO INSTALL

All the maintenance and installation activities are extremely easy, thanks to the profile configuration and to the hooking system for the rail profile and for all the components.

	ADVANCED EMERGENCY	HEAVY
Dimensions (mm):	125 x 156 x 6600	
Max load (kg):	1 leaf:140 2 leaves:120	1 leaf: 180 2 leaves:150
Max speed (m/s):	1 leaf:0.8 2 leaves:1.6	1 leaf:0.6 2 leaves:1.2
Service class	continuous operation	intense operation
Power supply:	100 - 240 V 50/60 Hz	
Power (W)	70	
Stand-by (W)	10	
Rated load (N)	150	
Degree of protection	IP20	
Operating temperature (°C)	-15 / +50	
Accessory output	12 Vdc (1 A max)	
Firmware update	USB standard / Micro SD	

**SL5** automation is a reference on the market for its silence thanks to the 3-gasket system that absorbs noise and vibrations. It also achieves the maximum level of energy efficiency through the use of the brushless motor in direct drive and to the switch mode technology.

The profiles system, the hooking system for the internal components and the integrated display make the installation very simple and easy.

**SL5** is available as **ADVANCED** or as **EMERGENCY** in redundant configuration or in the **HEAVY** version for leaves up to 180 kg.

